



Copy only  
(not for actual In-Cab usage)

# TABLE OF CONTENTS

GENERAL NOTES .....	4
WT. REDUCTIONS / LINE PULLS & REEVING INFO / HOIST PERFORMANCE .....	5
LIFTING AREA DIAGRAMS .....	6
RANGE DIAGRAM w/ FIXED EXTENSION .....	7
RANGE DIAGRAM w/ TELE EXTENSION .....	8
<b>ON OUTRIGGERS FULLY EXTENDED</b>	
MAIN BOOM .....	9
FIXED EXTENSION .....	10
TELE EXTENSION .....	11
<b>ON RUBBER .....</b>	<b>12 -13</b>
<b>ON OUTRIGGERS 50% EXTENDED</b>	
MAIN BOOM .....	14
FIXED EXTENSION .....	15
TELE EXTENSION .....	16
<b>ON OUTRIGGERS 0% EXTENDED</b>	
MAIN BOOM .....	17
TIRE INFLATION .....	18

# NOTES FOR LIFTING CAPACITIES

## GENERAL:

1. Rated loads as shown on lift chart pertain to this machine as originally manufactured and equipped. Modifications to the machine or use of optional equipment other than that specified can result in a reduction of capacity.
2. Construction equipment can be hazardous if improperly operated or maintained. Operation and maintenance of this machine shall be in compliance with the information in the Operator's and Safety Handbook, Service Manual and Parts Manual supplied with this machine. If these manuals are missing, order replacements from the manufacturer through the distributor.
3. The operator and other personnel associated with machine shall fully acquaint themselves with the latest American National Safety Standards (ASME/ANSI) for cranes.

## SETUP:

1. The machine shall be level and on a firm supporting surface. Depending on the nature of the supporting surface, it may be necessary to have structural supports under the outrigger floats or tires to spread the load to a larger bearing surface.
2. For outrigger operation, all outriggers shall be properly extended with tires raised free of crane weight before operating the boom or lifting loads.
3. When machine is equipped with center front stabilizer, the front stabilizer shall be set in accordance with instructions in Operator's and Safety Handbook.
4. When equipped with removable and/or extendible counterweight, the proper counterweight shall be installed and fully extended before and during operation.
5. Tires shall be inflated to the recommended pressure before lifting on rubber.
6. With certain boom and hoist tackle combinations, maximum capacities may not be obtainable with standard cable lengths.
7. Unless approved by the crane manufacturer, do not travel with boom extension or jib erected unless otherwise noted. Refer to Operator's and Safety Handbook for job-site travel information.

## OPERATION:

1. Rated loads at rated radius shall not be exceeded. Do not attempt to tip the machine to determine allowable loads. For clamshell, grapple, magnet or concrete bucket operation, weight of component and load must not exceed 80% of rated lifting capacities.
2. All rated loads have been tested to and meet the requirements of SAE J1063 - Cantilevered Boom Crane Structures - Method of Test, and do not exceed 85% of the tipping load on outriggers fully extended, and SAE J1289 - Mobile Crane Stability Ratings [1.25P < (T-0.1A)] on outriggers 50% and 0% extended (fully retracted) as determined by SAE J765 - Crane Stability Test Code.
3. Rated loads include the weight of hookblock, slings and auxiliary lifting devices and their weights shall be subtracted from the listed rating to obtain the net load to be lifted. When more than the minimum required parts of line needed to pick the load are used, the additional rope weight as measured from the lower sheaves of the the main boom nose shall be considered part of the load to be lifted. When both the hook block and headache ball are reeved, the lifting device that is NOT in use, including the line as measured from the lower sheave(s) of the nose supporting the unused device shall be considered part of the load.
4. Load ratings are based on freely suspended loads. No attempt shall be made to move a load horizontally on the ground in any direction.
5. The maximum in-service wind speed is 20 m.p.h. It is recommended when wind velocity is above 20 m.p.h., rated loads and boom lengths shall be appropriately reduced. For machines not in-service, the main boom should be retracted and lowered with the swing brake set in wind velocities over 30 m.p.h.
6. Rated loads are for lift crane service only.
7. Do not operate at a radius or boom length where capacities are not listed. At these positions, the machine may overturn without any load on the hook.
8. The maximum load which can be telescoped is not definable because of variations in loadings and crane maintenance, but it is safe to attempt retraction and extension of the boom within the limits of the capacity chart.
9. When the boom length or lift radius or both are between values listed, the smallest load shown at either the next larger radius or next longer or shorter boom length shall be used.
10. For safe operation, the user shall make due allowances for his particular job conditions, such as: soft or uneven ground, out of level conditions, high winds, side loads, pendulum action, jerking or sudden stopping of loads, experience of personnel, two machine (tandem) lifts, traveling with loads, electric wires, obstacles, hazardous conditions, etc. Side pull on boom or jib is extremely dangerous.
11. If machine is equipped with individually controlled powered boom sections, the boom sections must be extended equally at all times.
12. Never handle unless personnel with this machine unless the requirements of the applicable national, state, and local regulations and safety codes are met.
13. Keep load handling devices a minimum of 42 inches below boom head at all times.
14. The boom angle before loading should be greater than the loaded boom angle to account for deflection.
15. Capacities appearing above the bold line are based on structural strength and tipping should not be relied upon as a capacity limitation.
16. Capacities for the 32 ft. boom length shall be lifted with boom fully retracted. If boom is not fully retracted, capacities shall not exceed those shown for the 40 ft. boom length.
17. When operating the machine in the "On Outriggers 50% Extended (14' spread)" mode, the outrigger beam pins must be engaged. When operating in the "On Outriggers 0% Extended (7.8' spread)" mode, the outrigger beams must be fully retracted. Failure to follow these precautions could result in structural damage or loss of stability of the machine.
18. Regardless of counterweight and outrigger spread configuration, no deduct is required from the main boom charts for a stowed boom extension.
19. Do not lift loads when boom is fully lowered. The Load Moment Indicator (LMI) senses pressure and will not provide warnings or lockout. The crane can become overloaded if lift cylinder(s) is fully retracted.
20. The maximum outrigger pad load is 59,000 lb.

## DEFINITIONS:

1. Operating Radius: Horizontal distance from a projection of the axis of rotation to the supporting surface before loading to the center of the vertical hoist line or tackle with load applied.
2. Loaded Boom Angle (Shown in Parenthesis on Main Boom Capacity Chart): is the angle between the boom base section and the horizontal, after lifting the rated load at the rated radius with the rated boom length.
3. Working Area: Areas measured in a circular arc about the center line of rotation as shown on the working area diagram.
4. Freely Suspended Load: Load hanging free with no direct external force applied except by the lift cable.
5. Side Load: Horizontal force applied to the lifted load either on the ground or in the air.

## WEIGHT REDUCTIONS FOR LOAD HANDLING DEVICES

<b>26 FT. FIXED BOOM EXTENSION</b>	
*Erected -	2,750 lb.
<b>26 FT. - 45 FT. TELE. BOOM EXTENSION</b>	
*Erected (Retracted) -	3,750 lb.
*Erected (Extended) -	5,010 lb.

\*Reduction of main boom capacities

When lifting over boom extension, deduct total weight of all load handling devices reeved over main boom nose directly from boom extension capacity.

**NOTE:** All load handling devices and boom attachments are considered part of the load and suitable allowances **MUST BE MADE** for their combined weights. Weights are for Grove furnished equipment.

AUXILIARY BOOM NOSE	105 lb.
HOOKBLOCKS and HEADACHE BALLS:	
35 Ton, 3 Sheave (14" sheave)	623 lb.+
35 Ton, 3 Sheave (12" sheave)	599 lb.+
35 Ton, 4 Sheave (CE)	774 lb.+
7.5 Ton Overhaul Ball	369 lb.+

+Refer to rating plate for actual weight.

## LINE PULLS AND REEVING INFORMATION

HOISTS	CABLE SPECS.	PERMISSIBLE LINE PULLS	NOMINAL CABLE LENGTH
Main	5/8" (16 mm) 6x37 Class, EIPS, IWRC Special Flexible Min. Breaking Strength 41,200 lb.	11,640 lb.	450 ft.
Main & Aux.	5/8" (16 mm) Flex-X 35 Rotation Resistant (Non-rotating) Min. Breaking Strength 61,200 lb.	11,640 lb.	450 ft.

The approximate weight of 5/8" wire rope is 1.0 lb./ft.

## HOIST PERFORMANCE

Wire Rope Layer	Hoist Line Pulls		Drum Rope Capacity (ft.)	
	Two Speed Hoist			
	Low	High	Layer	Total
	Available lb.*	Available lb.*		
1	11,640	7,420	77	77
2	10,480	6,680	85	162
3	9,530	6,070	94	256
4	8,730	5,570	102	358
5	8,060	5,140	111	469
6	7,490	4,770	119	588

\*Max. lifting capacity: 6x37 and 35x7 class = 11,640 lb.

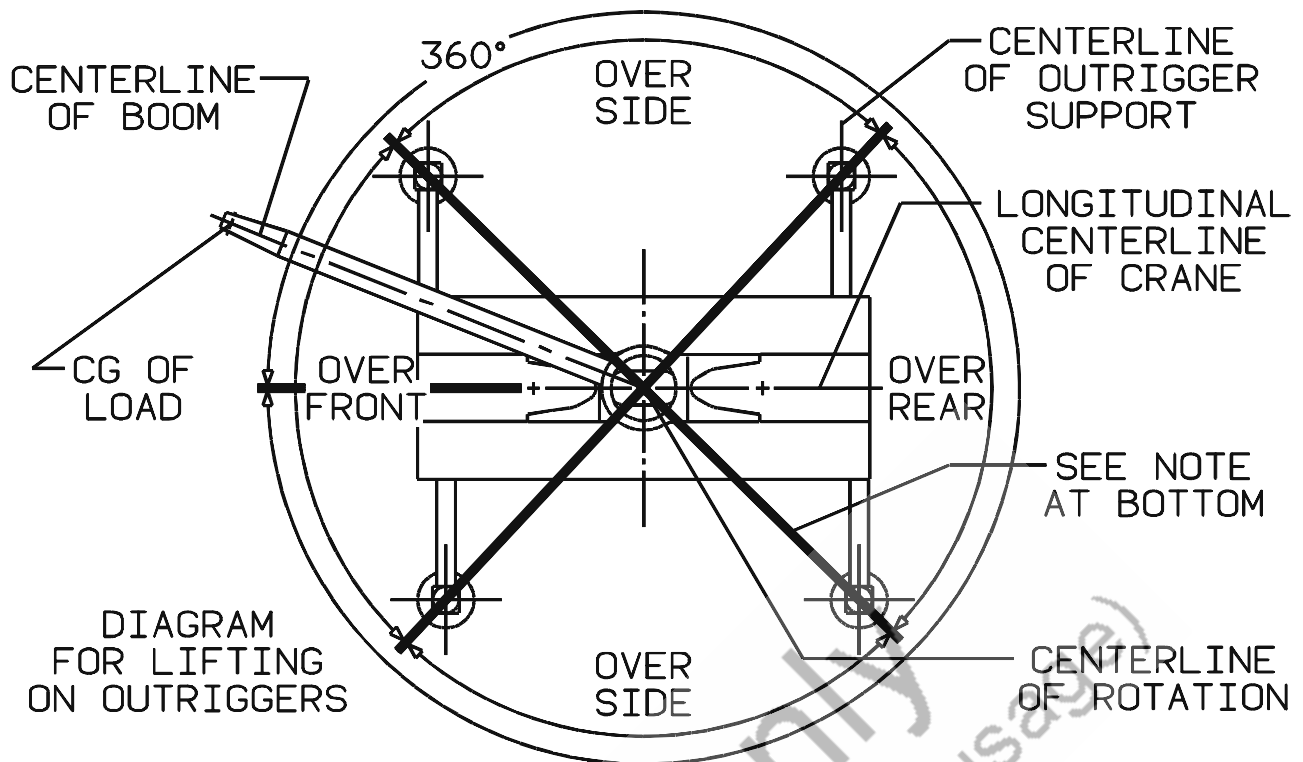

DIAGRAM FOR LIFTING ON OUTRIGGERS

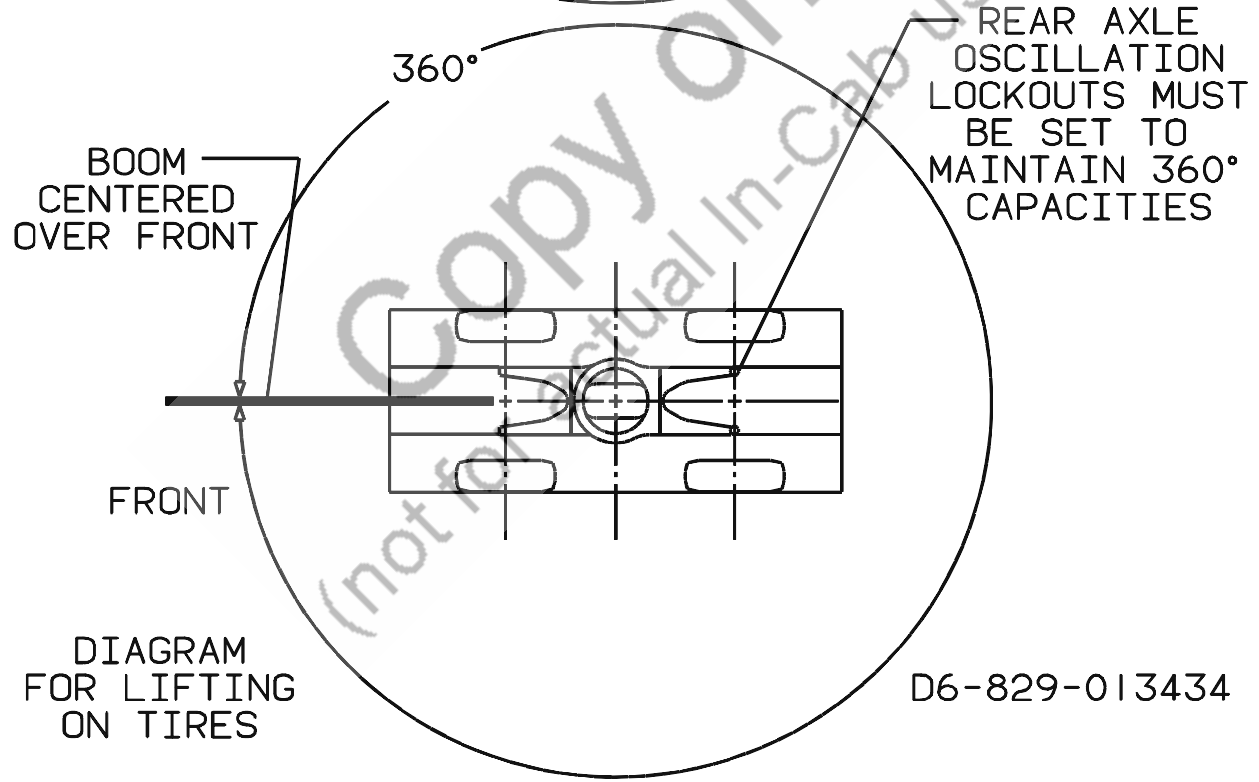

DIAGRAM FOR LIFTING ON TIRES

D6-829-013434

BOLD LINES DETERMINE THE LIMITING POSITION OF ANY LOAD FOR OPERATION WITHIN WORKING AREAS INDICATED  
 WORKING AREA DIAGRAM

# WORKING RANGE DIAGRAM

(BOOM DEFLECTION NOT SHOWN)

D6-829-104327

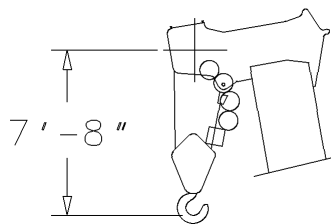
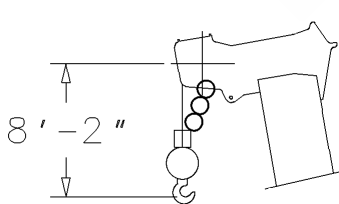
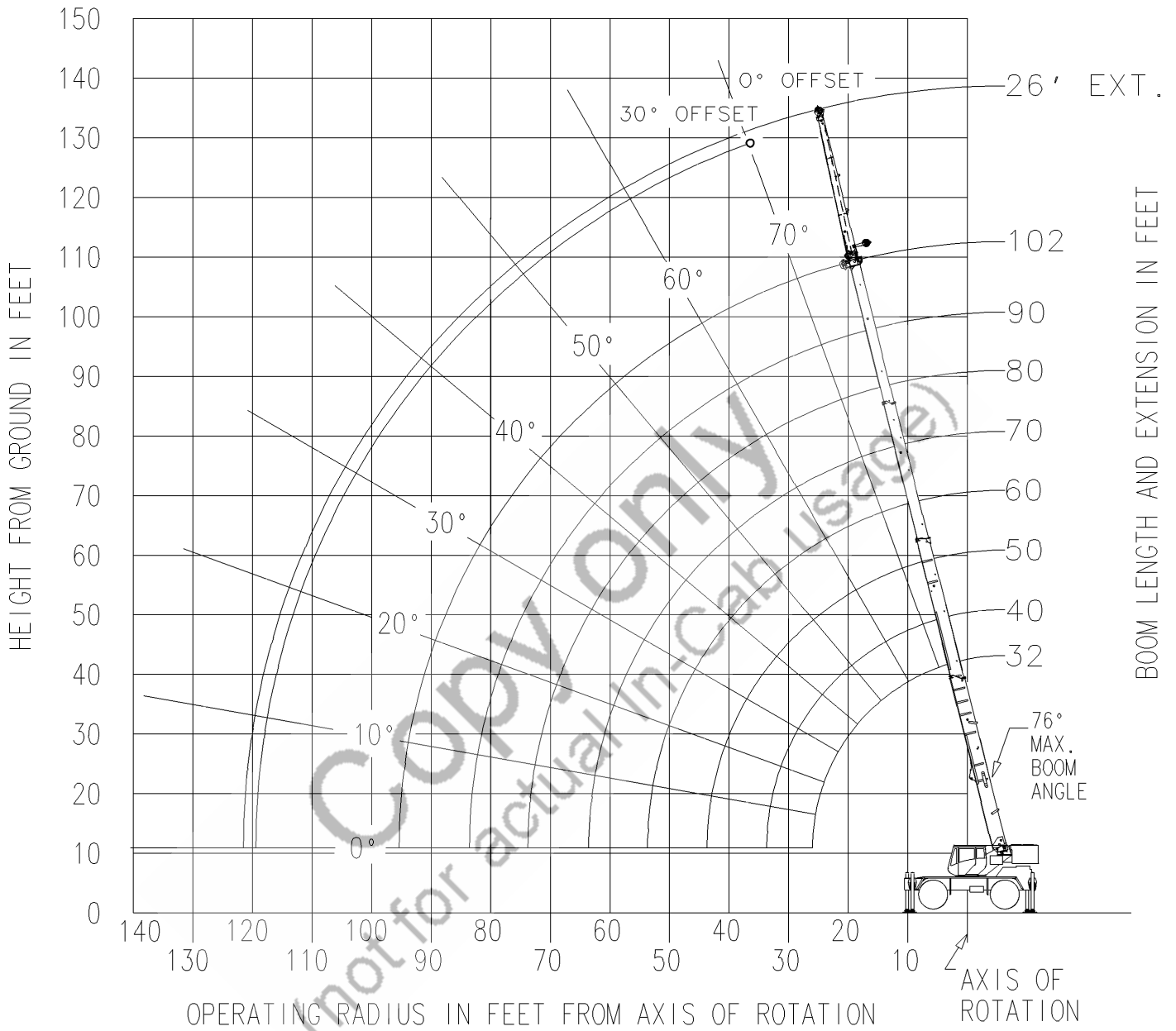

DIMENSIONS ARE FOR LARGEST GROVE FURNISHED HOOK BLOCK AND HEADACHE BALL, WITH ANTI-TWO BLOCK ACTIVATED.

# WORKING RANGE DIAGRAM

(BOOM DEFLECTION NOT SHOWN)

D6-829-103927

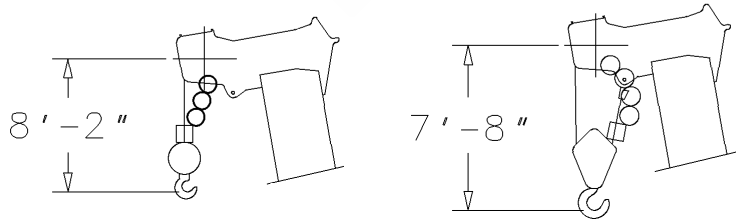
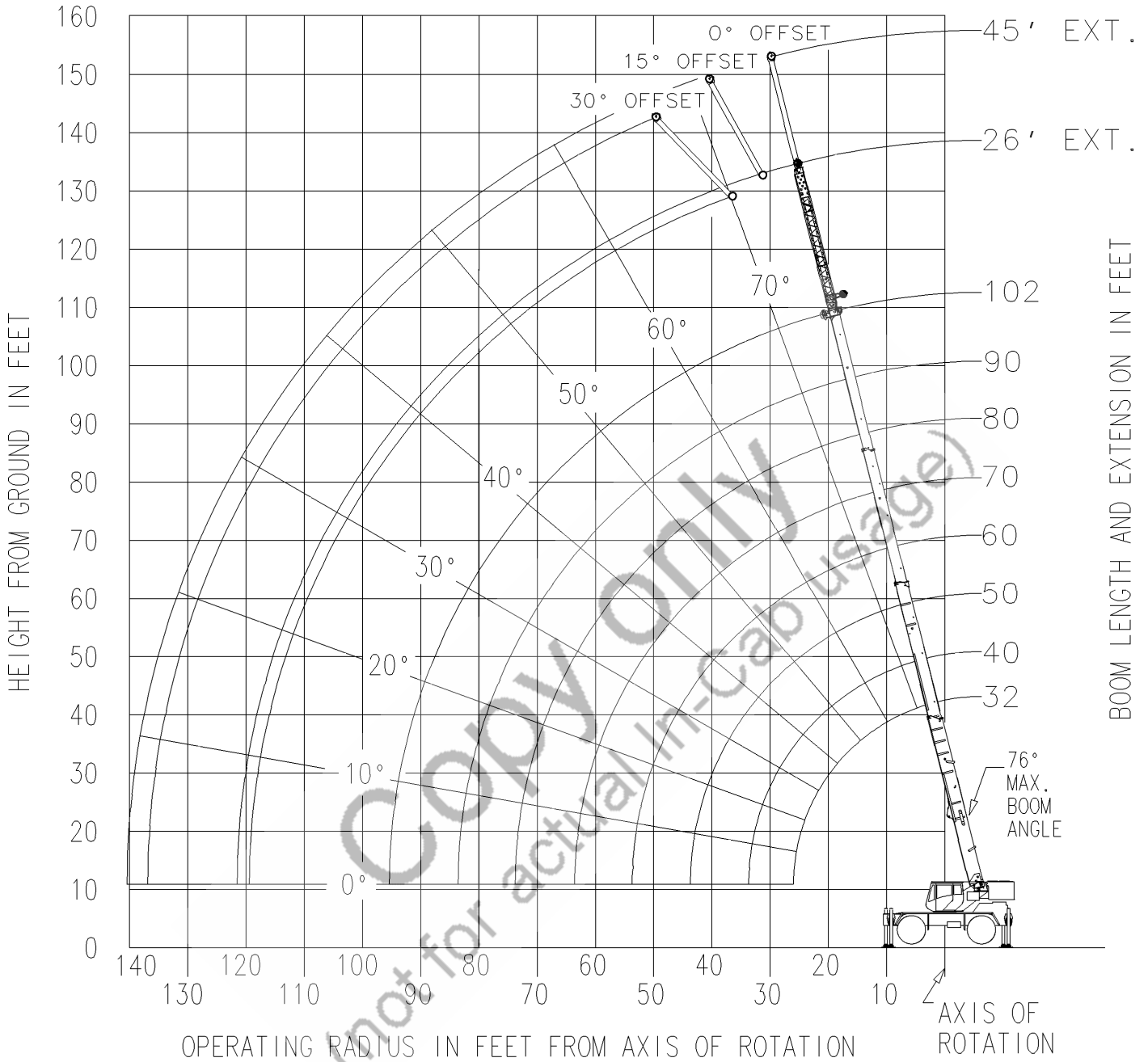

DIMENSIONS ARE FOR LARGEST GROVE FURNISHED HOOK BLOCK AND HEADACHE BALL, WITH ANTI-TWO BLOCK ACTIVATED.



**RATED LIFTING CAPACITIES IN POUNDS**  
**32 FT. - 102 FT. BOOM**  
**ON OUTRIGGERS FULLY EXTENDED - 360°**

Radius in Feet	#0001							
	Main Boom Length in Feet							
	32	40	50	60	70	80	90	102
8	80,000 (69)							
10	72,200 (65)	50,700 (70.5)	48,500 (75)					
12	61,000 (61)	50,700 (67.5)	48,500 (72.5)	*46,400 (76)				
15	47,950 (54)	48,400 (62.5)	48,500 (69)	44,300 (73)	*38,700 (76)			
20	34,550 (41)	35,000 (53.5)	35,400 (62.5)	35,300 (67.5)	31,000 (71.5)	29,700 (74)	*22,000 (76)	
25	26,300 (20.5)	26,800 (43.5)	27,200 (55.5)	27,400 (62.5)	25,800 (67)	24,600 (70.5)	22,000 (73)	*18,500 (76)
30		21,250 (30)	21,650 (47.5)	21,850 (56.5)	21,800 (62.5)	20,800 (66.5)	18,350 (69.5)	17,500 (73)
35			17,650 (38.5)	17,900 (50.5)	18,050 (57.5)	17,800 (62.5)	15,600 (66)	15,200 (70)
40	See Note 16		14,400 (26.5)	14,450 (43.5)	14,650 (52.5)	14,800 (58.5)	13,500 (62.5)	13,200 (66.5)
45				11,650 (35)	11,800 (46.5)	11,900 (54)	11,750 (59)	11,600 (63.5)
50				9,480 (24.5)	9,680 (40.5)	9,770 (49)	9,780 (55)	9,790 (60.5)
55					7,970 (33)	8,080 (44)	8,110 (51)	8,130 (57)
60					6,600 (23)	6,720 (38)	6,770 (46.5)	6,800 (53.5)
65						5,590 (31)	5,670 (42)	5,710 (49.5)
70						4,640 (21.5)	4,740 (36)	4,800 (45.5)
75							3,940 (29.5)	4,040 (41)
80							3,250 (21)	3,360 (36)
85								2,770 (30.5)
90								2,250 (23)
95								1,800 (9.5)
Minimum boom angle (°) for indicated length (no load)								0
Maximum boom length (ft.) at 0° boom angle (no load)								102

NOTE: ( ) Boom angles are in degrees.

#LMI operating code. Refer to LMI manual for operating instructions.

\*This capacity is based on maximum boom angle.

Lifting Capacities at Zero Degree Boom Angle								
Boom Angle	Main Boom Length in Feet							
	32	40	50	60	70	80	90	102
0°	24,950 (26)	18,100 (33.8)	12,150 (43.8)	8,180 (53.8)	5,740 (63.8)	4,030 (73.8)	2,800 (83.8)	1,760 (95.5)

NOTE: ( ) Reference radii in feet.

A6-829-104278

**26 FT. FIXED OFFSETTABLE EXTENSION  
ON OUTRIGGERS FULLY EXTENDED - 360°**

Radius in Feet	26 ft. LENGTH	
	#0051	#0053
	0° OFFSET	30° OFFSET
35	*8,200 (76)	
40	8,200 (72.5)	
45	8,200 (70)	*5,780 (76)
50	8,150 (67.5)	5,780 (72.5)
55	7,500 (65)	5,450 (70)
60	6,440 (62.5)	4,910 (67.5)
65	5,460 (60)	4,450 (64.5)
70	4,620 (57.5)	4,050 (62)
75	3,900 (54.5)	3,670 (59)
80	3,260 (51.5)	3,350 (56)
85	2,710 (48.5)	3,100 (53)
90	2,210 (45)	2,580 (49.5)
95	1,770 (41.5)	2,080 (46)
100	1,380 (38)	1,620 (41.5)
105	1,020 (33.5)	1,200 (37)
Min. boom angle for indicated length (no load)	32°	36°
Max. boom length at 0° boom angle (no load)	80 ft.	

A6-829-104329

NOTE: ( ) Boom angles are in degrees.  
#LMI operating code. Refer to LMI manual for instructions.

\*This capacity based on maximum boom angle.

**BOOM EXTENSION CAPACITY NOTES:**

1. All capacities above the bold line are based on structural strength of boom extension.
2. 26 ft. fixed extension length may be used for single line lifting service.
3. Radii listed are for a fully extended boom with the boom extension erected. For main boom lengths less than fully extended, the rated loads are determined by boom angle. Use only the column which corresponds to the boom extension length and offset for which the machine is configured. For boom angles not shown, use the rating of the next lower boom angle.

**WARNING:** Operation of this machine with heavier loads than the capacities listed is strictly prohibited. Machine tipping with boom extension occurs rapidly and without advance warning.

4. Boom angle is the angle above or below horizontal of the longitudinal axis of the boom base section after lifting rated load.
5. Capacities listed are with outriggers properly extended and vertical jacks set only.
6. When lifting over the main boom nose with 26 ft. fixed extension erected, the outriggers must be fully extended or 50% extended (14' spread).

**26 FT. - 45 FT. TELE OFFSETTABLE BOOM EXTENSION  
ON OUTRIGGERS FULLY EXTENDED - 360°**

Radius in Feet	26 ft. LENGTH			45 ft. LENGTH		
	#0021	#0022	#0023	#0041	#0042	#0043
	0° OFFSET	15° OFFSET	30° OFFSET	0° OFFSET	15° OFFSET	30° OFFSET
35	*10,200 (76)					
40	9,460 (72.5)	*7,770 (76)		*5,250 (76)		
45	8,760 (70)	7,370 (72)	*6,030 (76)	5,250 (73.5)		
50	8,150 (67.5)	6,870 (69.5)	5,780 (72.5)	5,050 (71.5)	3,660 (76)	
55	7,510 (65)	6,050 (67)	5,520 (70)	4,650 (69.5)	3,540 (72.5)	
60	6,700 (62.5)	5,350 (64.5)	5,290 (67.5)	4,290 (67)	3,430 (70.5)	*3,000 (76)
65	5,990 (60)	4,740 (62)	4,810 (64.5)	4,000 (65)	3,320 (68.5)	2,890 (72.5)
70	5,240 (57.5)	4,210 (59)	4,270 (62)	3,800 (63)	3,220 (66)	2,790 (70.5)
75	4,400 (54.5)	3,750 (56)	3,800 (59)	3,650 (60.5)	3,130 (64)	2,700 (68)
80	3,670 (51.5)	3,330 (53.5)	3,380 (56)	3,520 (58.5)	3,000 (61.5)	2,620 (65.5)
85	3,050 (48.5)	2,960 (50.5)	3,010 (53)	3,360 (56)	2,880 (59)	2,550 (63)
90	2,500 (45)	2,590 (47)	2,670 (49.5)	3,030 (53.5)	2,770 (56.5)	2,480 (60.5)
95	2,020 (41.5)	2,130 (43.5)	2,270 (46)	2,640 (51)	2,680 (54)	2,410 (57.5)
100	1,590 (38)	1,680 (40)	1,790 (41.5)	2,270 (48)	2,570 (51.5)	2,380 (55)
105	1,200 (33.5)	1,280 (35.5)	1,360 (37)	1,930 (45.5)	2,260 (48.5)	2,310 (52)
110				1,630 (42.5)	1,890 (45.5)	2,030 (48.5)
115				1,330 (39)	1,550 (42)	1,700 (45)
120				1,040 (35.5)	1,240 (38.5)	1,400 (41)
125						1,080 (36.5)
Min. boom angle for indicated length (no load)	29°	30.5°	36°	34°	34.5°	35°
Max. boom length at 0° boom angle (no load)	80 ft.			80 ft.		

NOTE: ( ) Boom angles are in degrees.

A6-829-104322

#LMI operating code. Refer to LMI manual for instructions.

\*This capacity based on maximum boom angle.

**BOOM EXTENSION CAPACITY**

**NOTES:**

1. All capacities above the bold line are based on structural strength of boom extension.
2. 26 ft. and 45 ft. tele extension lengths may be used for single line lifting service.
3. Radii listed are for a fully extended boom with the boom extension erected. For main boom lengths less than fully extended, the rated loads are determined by boom angle. Use only the column which corresponds to the boom extension length and offset for which the machine is configured. For boom angles not shown, use the rating of the next lower boom angle.

**WARNING:** Operation of this machine with heavier loads than the capacities listed is strictly prohibited. Machine tipping with boom extension occurs rapidly and without advance warning.

4. Boom angle is the angle above or below horizontal of the longitudinal axis of the boom base section after lifting rated load.
5. Capacities listed are with outriggers properly extended and vertical jacks set only.
6. When lifting over the main boom nose with 26 ft. or 45 ft. tele extension erected, the outriggers must be fully extended or 50% extended (14' spread).

# ON RUBBER CAPACITIES

## STATIONARY CAPACITIES - 360°

Radius in Feet	<b>#9005</b>			
	Main Boom Length in Feet			
	32	40	50	60
10	24,050 (65)	24,100 (70.5)	23,000 (76)	
12	21,600 (61)	22,050 (67.5)	21,600 (72.5)	
15	15,250 (54)	15,550 (62.5)	16,100 (68.5)	13,900 (72.5)
20	9,110 (41)	9,380 (53.5)	9,860 (62)	9,860 (67.5)
25	5,790 (20)	6,050 (43)	6,400 (55)	6,510 (62)
30		3,970 (29.5)	4,240 (47.5)	4,370 (56)
35			2,770 (38)	2,900 (50)
40			1,690 (26)	1,840 (43)
45				1,030 (34.5)
Minimum boom angle (°) for indicated length (no load)				33
Maximum boom length (ft.) at 0° boom angle (no load)				50

NOTE: ( ) Boom angles are in degrees.  
 #LMI operating code. Refer to LMI manual for operating instructions.

<b>Lifting Capacities at Zero Degree Boom Angle</b>				
Boom Angle	Main Boom Length in Feet			
	32	40	50	
0°	5,290 (26)	2,850 (33.8)	1,060 (43.8)	

NOTE: ( ) Reference radii in feet.

A6-829-104281

## ON RUBBER CAPACITIES (cont'd.)

PICK & CARRY CAPACITIES (UP TO 2.5 MPH) -  
BOOM CENTERED OVER FRONT (See note 6)

Radius in Feet	<b>#9006</b>			
	Main Boom Length in Feet			
	32	40	50	60
10	27,150 (65)	26,900 (70.5)		
12	23,350 (61)	23,250 (67.5)		
15	18,950 (54)	19,100 (62.5)	19,400 (69)	
20	13,700 (41)	14,200 (53.5)	14,500 (62.5)	14,550 (67.5)
25	10,100 (20)	10,750 (43.5)	11,150 (55.5)	11,200 (62)
30		8,290 (30)	8,620 (47.5)	8,790 (56.5)
35			6,710 (38.5)	6,890 (50)
40			5,210 (26.5)	5,390 (43)
45				4,180 (35)
50				3,190 (24)
Minimum boom angle (°) for indicated length (no load)				0
Maximum boom length (ft.) at 0° boom angle (no load)				60

NOTE: ( ) Boom angles are in degrees.  
#LMI operating code. Refer to LMI manual for operating instructions.

<b>Lifting Capacities at Zero Degree Boom Angle</b>				
Boom Angle	Main Boom Length in Feet			
	32	40	50	60
0°	9,520 (26)	6,830 (33.8)	4,280 (43.8)	2,560 (53.8)

NOTE: ( ) Reference radii in feet.

### NOTES TO ALL RUBBER CAPACITY CHARTS:

- Capacities are in pounds and do not exceed 75% of tipping loads as determined by test in accordance with SAE J765.
- Capacities are applicable to machines equipped with 20.5x25 (24 ply) tires at 75 psi cold inflation pressure, and 16.00x25 (28 ply) tires at 100 psi cold inflation pressure.
- Capacities appearing above the bold line are based on structural strength and tipping should not be relied upon as a capacity limitation.
- Capacities are applicable only with machine on firm level surface.
- On rubber lifting with boom extensions not permitted.
- For pick and carry operation, boom must be centered over front of machine, mechanical swing lock engaged and load restrained from swinging. When handling loads in the structural range with capacities close to maximum ratings, travel should be reduced to creep speeds.
- Axle lockouts must be functioning when lifting on rubber.
- All lifting depends on proper tire inflation, capacity and condition. Capacities must be reduced for lower tire inflation pressures. See lifting capacity chart for tire used. Damaged tires are hazardous to safe operation of crane.
- Creep - not over 200 ft. of movement in any 30 minute period and not exceeding 1 mph.

A6-829-104282

## RATED LIFTING CAPACITIES IN POUNDS

32 FT. - 102 FT. BOOM

ON OUTRIGGERS 50% EXTENDED (14 ft. spread) - 360°

Radius in Feet	<b>#4001</b>							
	Main Boom Length in Feet							
	32	40	50	60	70	80	90	102
8	77,000 (69)							
10	66,250 (65)	50,700 (70.5)	48,500 (75)					
12	57,950 (61)	50,700 (67.5)	48,500 (72.5)	*46,400 (76)				
15	46,300 (54)	44,200 (62.5)	41,800 (69)	39,550 (73)	*37,550 (76)			
20	27,100 (41)	27,700 (53.5)	27,050 (62.5)	25,950 (67.5)	24,950 (71.5)	24,000 (74)	*22,000 (76)	
25	17,650 (20.5)	18,250 (43.5)	18,500 (55.5)	18,450 (62.5)	18,050 (67)	17,450 (70.5)	16,950 (73)	*16,350 (76)
30		12,850 (30)	13,200 (47.5)	13,300 (56.5)	13,550 (62.5)	13,250 (66.5)	12,950 (69.5)	12,500 (73)
35	See Note 16		9,790 (38.5)	9,910 (50.5)	10,150 (57.5)	10,250 (62.5)	10,100 (66)	9,830 (70)
40			7,400 (26.5)	7,520 (43.5)	7,770 (52.5)	7,910 (58.5)	7,950 (62.5)	7,820 (66.5)
45				5,760 (35)	5,970 (46.5)	6,150 (54)	6,180 (59)	6,190 (63.5)
50				4,410 (24.5)	4,590 (40.5)	4,750 (49)	4,820 (55)	4,850 (60.5)
55					3,500 (33)	3,630 (44)	3,710 (51)	3,780 (57)
60					2,610 (23)	2,730 (38)	2,810 (46.5)	2,890 (53.5)
65						1,980 (31)	2,070 (42)	2,150 (49.5)
70						1,350 (21.5)	1,440 (36)	1,530 (45.5)
75								1,000 (41)
Minimum boom angle (°) for indicated length (no load)						0	21	36
Maximum boom length (ft.) at 0° boom angle (no load)						80		

NOTE: ( ) Boom angles are in degrees.

#LMI operating code. Refer to LMI manual for operating instructions.

\*This capacity is based on maximum boom angle.

<b>Lifting Capacities at Zero Degree Boom Angle</b>								
Boom Angle	Main Boom Length in Feet							
	32	40	50	60	70			
0°	16,300 (26)	10,150 (33.8)	6,030 (43.8)	3,580 (53.8)	2,050 (63.8)			

NOTE: ( ) Reference radii in feet.

A6-829-104279

**26 FT. FIXED OFFSETTABLE EXTENSION**  
**ON OUTRIGGERS 50% EXTENDED (14 ft. spread) - 360°**

Radius in Feet	26 ft. LENGTH	
	#4051	#4053
	0° OFFSET	30° OFFSET
35	*8,200 (76)	
40	7,240 (72.5)	
45	5,780 (70)	*5,780 (76)
50	4,610 (67.5)	5,740 (72.5)
55	3,650 (65)	4,650 (70)
60	2,850 (62.5)	3,720 (67.5)
65	2,140 (60)	2,900 (64.5)
70	1,540 (57.5)	2,210 (62)
75	1,030 (54.5)	1,620 (59)
80		1,100 (56)
Min. boom angle for indicated length (no load)	51.5°	53°
Max. boom length at 0° boom angle (no load)	60 ft.	

A6-829-104330

NOTE: ( ) Boom angles are in degrees.  
 #LMI operating code. Refer to LMI manual for instructions.  
 \*This capacity based on maximum boom angle.

**BOOM EXTENSION CAPACITY NOTES:**

1. All capacities above the bold line are based on structural strength of boom extension.
2. 26 ft. fixed extension length may be used for single line lifting service.
3. Radii listed are for a fully extended boom with the boom extension erected. For main boom lengths less than fully extended, the rated loads are determined by boom angle. Use only the column which corresponds to the boom extension length and offset for which the machine is configured. For boom angles not shown, use the rating of the next lower boom angle.  
  
 WARNING: Operation of this machine with heavier loads than the capacities listed is strictly prohibited. Machine tipping with boom extension occurs rapidly and without advance warning.
4. Boom angle is the angle above or below horizontal of the longitudinal axis of the boom base section after lifting rated load.
5. Capacities listed are with outriggers properly extended and vertical jacks set only.
6. When lifting over the main boom nose with 26 ft. fixed extension erected, the outriggers must be fully extended or 50% extended (14' spread).

## 26 FT. - 45 FT. TELE BOOM EXTENSION

### ON OUTRIGGERS 50% EXTENDED (14 ft. spread) - 360°

Radius in Feet	26 ft. LENGTH			45 ft. LENGTH		
	#4021	#4022	#4023	#4041	#4042	#4043
	0° OFFSET	15° OFFSET	30° OFFSET	0° OFFSET	15° OFFSET	30° OFFSET
35	*9,120 (76)					
40	7,240 (72.5)	*7,770 (76)		*5,250 (76)		
45	5,780 (70)	6,460 (72)	*6,030 (76)	5,250 (73.5)		
50	4,610 (67.5)	5,200 (69.5)	5,740 (72.5)	5,050 (71.5)	3,660 (76)	
55	3,650 (65)	4,180 (67)	4,650 (70)	4,280 (69.5)	3,540 (72.5)	
60	2,850 (62.5)	3,320 (64.5)	3,720 (67.5)	3,480 (67)	3,430 (70.5)	*3,000 (76)
65	2,140 (60)	2,550 (62)	2,900 (64.5)	2,820 (65)	3,320 (68.5)	2,890 (72.5)
70	1,540 (57.5)	1,900 (59)	2,210 (62)	2,260 (63)	2,880 (66)	2,790 (70.5)
75	1,030 (54.5)	1,350 (56)	1,620 (59)	1,740 (60.5)	2,300 (64)	2,700 (68)
80			1,100 (56)	1,300 (58.5)	1,800 (61.5)	2,240 (65.5)
85					1,360 (59)	1,750 (63)
90						1,320 (60.5)
Min. boom angle for indicated length (no load)	51.5°	53.5°	53°	56°	56.5°	57.5°
Max. boom length at 0° boom angle (no load)	60 ft.			60 ft.		

NOTE: ( ) Boom angles are in degrees.

A6-829-104323

#LMI operating code. Refer to LMI manual for instructions.

\*This capacity based on maximum boom angle.

#### BOOM EXTENSION CAPACITY NOTES:

1. All capacities above the bold line are based on structural strength of boom extension.
2. 26 ft. and 45 ft. tele extension lengths may be used for single line lifting service.
3. Radii listed are for a fully extended boom with the boom extension erected. For main boom lengths less than fully extended, the rated loads are determined by boom angle. Use only the column which corresponds to the boom extension length and offset for which the machine is configured. For boom angles not shown, use the rating of the next lower boom angle.

**WARNING:** Operation of this machine with heavier loads than the capacities listed is strictly prohibited. Machine tipping with boom extension occurs rapidly and without advance warning.

4. Boom angle is the angle above or below horizontal of the longitudinal axis of the boom base section after lifting rated load.
5. Capacities listed are with outriggers properly extended and vertical jacks set only
6. When lifting over the main boom nose with 26 ft. or 45 ft. tele extension erected, the outriggers must be fully extended or 50% extended (14' spread).



**RATED LIFTING CAPACITIES IN POUNDS**  
**32 FT. - 102 FT. BOOM**

ON OUTRIGGERS 0% EXTENDED (7.8 ft. spread) - 360°

Radius in Feet	<b>#8001</b>							
	Main Boom Length in Feet							
	32	40	50	60	70	80	90	102
8	51,950 (69)							
10	37,800 (65)	35,900 (70.5)	33,600 (75)					
12	29,050 (61)	28,100 (67.5)	26,600 (72.5)	*25,150 (76)				
15	20,850 (54)	20,450 (62.5)	19,750 (69)	18,850 (73)	*18,000 (76)			
20	12,500 (41)	13,050 (53.5)	12,950 (62.5)	12,600 (67.5)	12,150 (71.5)	11,700 (74)	*11,250 (76)	
25	7,950 (20.5)	8,460 (43.5)	8,700 (55.5)	8,760 (62.5)	8,580 (67)	8,300 (70.5)	8,050 (73)	*7,720 (76)
30		5,610 (30)	5,890 (47.5)	6,000 (56.5)	6,110 (62.5)	5,980 (66.5)	5,840 (69.5)	5,600 (73)
35	See Note 16		3,980 (38.5)	4,090 (50.5)	4,350 (57.5)	4,270 (62.5)	4,200 (66)	4,060 (70)
40			2,600 (26.5)	2,710 (43.5)	2,940 (52.5)	2,970 (58.5)	2,940 (62.5)	2,850 (66.5)
45				1,670 (35)	1,860 (46.5)	1,960 (54)	1,950 (59)	1,890 (63.5)
50					1,020 (40.5)	1,160 (49)	1,160 (55)	1,110 (60.5)
Minimum boom angle (°) for indicated length (no load)				0	33	44	51	57
Maximum boom length (ft.) at 0° boom angle (no load)				60				

NOTE: ( ) Boom angles are in degrees.

#LMI operating code. Refer to LMI manual for operating instructions.

\*This capacity is based on maximum boom angle.

<b>Lifting Capacities at Zero Degree Boom Angle</b>								
Boom Angle	Main Boom Length in Feet							
	32	40	50					
0°	7,230 (26)	4,060 (33.8)	1,790 (43.8)					

NOTE: ( ) Reference radii in feet.

A6-829-104280

TIRE INFLATION - PSI (BAR)

SIZE (FRONT & REAR)	LOAD RANGE	TRA CODE	LIFTING SERVICE AND GENERAL TRAVEL	EXTENDED TRAVEL
			STATIC, CREEP & 2.5 MPH (4.0 km/h)	
20.5x25	24 PR	E-3	75 (5.2)	70 (4.8)
16.00x25	28 PR	E-3	100 (6.9)	95 (6.6)

Copy only  
(not for actual in-cab usage)